



Classified by
Underwriters Laboratories, Inc.
to UL 2079 and CAN/ULC-S115

System No. HW-D-0082

ANSI/UL2079	CAN/ULC S115
Assembly Rating — 1 and 2 Hr (See Items 2 and 3)	F Rating — 1 and 2 Hr (See Items 2 and 3)
Nominal Joint Width - 3/4 In.	FT Rating — 1 and 2 Hr (See Items 2 and 3)
Class II Movement Capabilities - 33% Compression or Extension	FH Rating — 1 and 2 Hr (See Items 2 and 3)
	FTH Rating — 1 and 2 Hr (See Items 2 and 3)
	Nominal Joint Width - 3/4 In.
	Class II Movement Capabilities - 33% Compression or Extension

HWD 0082

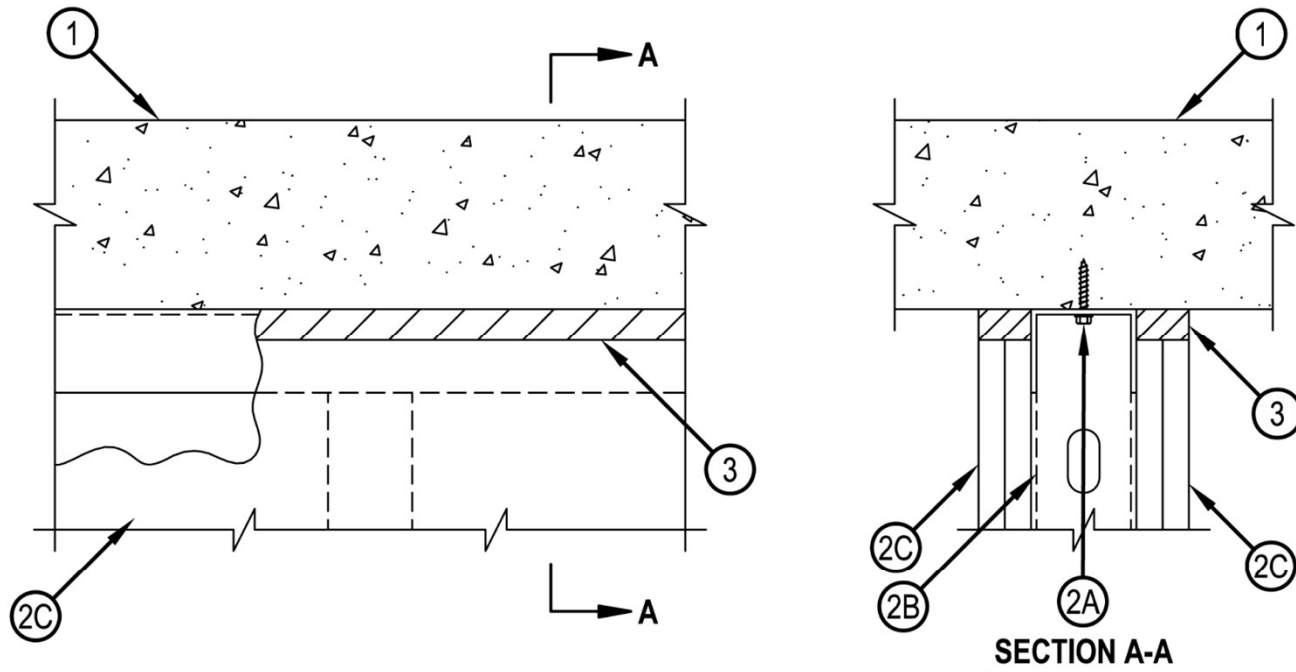

1. Floor Assembly — Min 4-1/2 in. (114 mm) thick reinforced lightweight or normal weight (100-150 pcf or 1600-2400 kg/m³) structural concrete.
2. Wall Assembly — The 1 or 2 h fire-rated gypsum board /steel stud wall assembly shall be constructed of the materials and in the manner specified in the individual U400 or V400 Series Wall and Partition Design in the UL Fire Resistance Directory and shall include the following construction features:
 - A. Steel Floor and Ceiling Runners — Floor and ceiling runners of wall assembly shall consist of min No. 25 gauge galv steel channels sized to accommodate steel studs (Item 2B). Flange height of ceiling runner shall be min 1/4 in. (6 mm) greater than max extended joint width Ceiling runner secured to concrete floor slab with steel masonry anchors or steel fasteners spaced 24 in. (610 mm) OC.



Hilti Firestop Systems

Reproduced by HILTI, Inc. Courtesy of
Underwriters Laboratories, Inc.
April 07, 2015

System No. HW-D-0082

- A1. Light Gauge Framing*-Slotted Ceiling Runner — As an alternate to the ceiling runner in Item 2A, slotted ceiling runner to consist of galv steel channel with slotted flanges sized to accommodate steel studs (Item 2B). Slotted ceiling runner secured to concrete floor slab with steel masonry anchors spaced max 24 in. (610 mm) OC.
BRADY CONSTRUCTION INNOVATIONS INC, DBA SLIPTRACK SYSTEMS — SLP-TRK
CALIFORNIA EXPANDED METAL PRODUCTS CO — CST
CLARKDIETRICH BUILDING SYSTEMS — Type SLT, SLT-H
MARINO/WARE, DIV OF WARE INDUSTRIES INC — Type SLT
SCAFCO STEEL STUD MANUFACTURING CO
TELLING INDUSTRIES L L C — True-Action Deflection Track
 - A2. Light Gauge Framing*-Vertical Deflection Ceiling Runner — As an alternate to the ceiling runners in Items 2A and 2A1, vertical deflection ceiling runner to consist of galv steel channel with slotted vertical deflection clips mechanically fastened within runner. Slotted clips, provided with step bushings, for permanent fastening of steel studs. Flanges sized to accommodate steel studs (Item 2B). Vertical deflection ceiling runner secured to concrete floor slab with steel masonry anchors or steel fasteners spaced max 24 in. (610 mm) OC.
THE STEEL NETWORK INC — VeriTrack VTD250, VTD362, VTD400, VTD600 and VTD800
 - A3. Light Gauge Framing* - Notched Ceiling Runner — As an alternate to the ceiling runners in Items 2A through 2A3, notched ceiling runners to consist of C-shaped galv steel channel with notched return flanges sized to accommodate steel studs (Item 2B). Notched ceiling runner secured to concrete floor slab with steel masonry anchors or steel fasteners spaced max 24 in. (610 mm) OC.
OLMAR SUPPLY INC — Type SCR
- B. Studs — Steel studs to be min 2-1/2 in. (64 mm) wide. Studs cut 1/2 to 3/4 in. (13 to 19 mm) less in length than assembly height with bottom nesting in and resting on floor runner and with top nesting in ceiling runner without attachment. When slotted ceiling runner (Item 2A1) is used, steel studs secured to slotted ceiling runner with No. 8 by 1/2 in. (13 mm) long wafer head steel screws at midheight of slot on each side of wall. Stud spacing not to exceed 24 in. (610 mm) OC. When vertical deflection ceiling runner (Item 2A2) is used, steel studs secured to slotted vertical deflection clips, through the bushings, with steel screws at midheight of each slot. Stud spacing not to exceed 24 in. (610 mm) OC.
- C. Gypsum Board* — Gypsum board installed to a min total thickness 5/8 or 1-1/4 in. (16 or 32 mm) on each side of wall, for 1 or 2 hr fire resistance rated walls, respectively. Wall to be constructed as specified in the individual U400 or V400 Series Design in the UL Fire Resistance Directory, except that a max 3/4 in. (19 mm) gap shall be maintained between the top of gypsum board and bottom of concrete floor. The screws attaching the gypsum board to the studs at the top of the first layer shall be located 4 in. (102 mm) from the steel floor unit valleys. The screws attaching the second layer to the steel studs shall be installed into the studs 3-1/2 in. (89 mm) below the valleys of the steel floor units. The hourly fire rating of the joint system is dependent on the hourly ratings of the walls.
2. Fill, Void or Cavity Material — Sealant — Max separation between the bottom of floor and top of wall is 3/4 in. (19 mm). The joint system is designed to accommodate a max 33 percent compression or extension from its installed width. Fill material installed on each side of wall between the top of the gypsum board and the bottom of the concrete floor. Min 5/8 in. (16 mm) thickness plus a 1/4 in. (6 mm) crown required for 1 hr fire rated system. Min 1-1/4 in. (32 mm) thickness installed flush with surface of wall required for 2 Hr fire rated system.
HILTI CONSTRUCTION CHEMICALS, DIV OF HILTI INC — CP601S Elastomeric Firestop Sealant or CFS-S SIL GG Sealant

* Indicates such products shall bear the UL or cUL Certification Mark for jurisdictions employing the UL or cUL Certification (such as Canada), respectively.

HWD 0082



Hilti Firestop Systems

Reproduced by HILTI, Inc. Courtesy of
Underwriters Laboratories, Inc.
April 07, 2015