



System No. W-J-1214

WJ 1214

Classified by Underwriters Laboratories, Inc. to UL 1479 and CAN/ULC-S115

ANSI/UL1479 (ASTM E814)	CAN/ULC S115
F Rating — 2 Hr	F Rating — 2 Hr
T Rating — 0 Hr	FT Rating — 0 Hr
	FH Rating — 2 Hr
	FTH Rating — 0 Hr

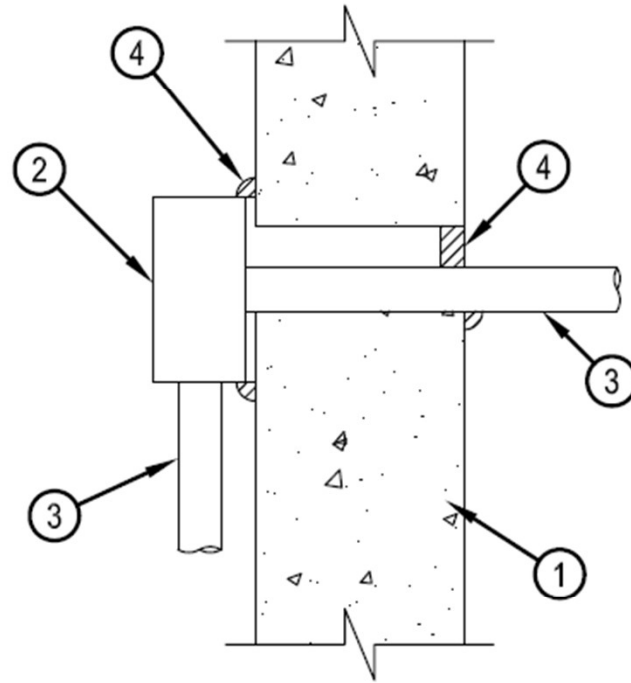
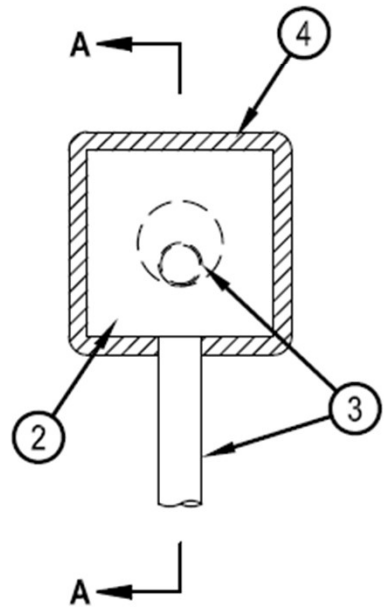

SECTION A-A

1. Wall Assembly — Min 5-5/8 in. (143 mm) reinforced lightweight or normal weight (100-150 pcf or 1600-2400 kg/m³) concrete. Wall may also be constructed of any UL Classified Concrete Blocks*. Diam of opening to be min 1/2 in. (13 mm) larger than outside diam of through penetrant. Max diam of opening is 2-1/4 in. (57 mm).

See Concrete Blocks (CAZT) category in the Fire Resistance Directory for names of manufacturers.

2. Pull or Junction Box+ — Min 16 ga steel pull or junction box mounted flush with or max 1/4 in. (6 mm) from surface of wall.

See Junction and Pull Boxes (BGUZ) category in the Electrical Construction Material Directory for names of manufacturers.

3. Conduit — One nom 1 in. (25 mm) diam (or smaller) steel conduit or steel electrical metallic tubing to be installed either concentrically or eccentrically within the firestop system. The annular space shall be min 0 in. (point contact) to max 1-1/8 in. (29 mm). Conduit or EMT to be secured to back surface of pull or junction box with steel connector and rigidly supported on both sides of wall assembly.

4. Fill, Void or Cavity Material* — Sealant — Min 5/8 in. (16 mm) thickness of fill material applied within the annulus, flush with surface of wall opposite the pull or junction box. A min 1/2 in. (13 mm) diam bead of fill material shall be applied at the point contact location between the conduit and wall. A min 1/2 in. (13 mm) diam bead of fill material shall be applied around the entire perimeter of the pull or junction box at its interface with the wall surface. The fill material shall lap min 1/2 in. (13 mm) onto both the wall and sides of the pull or junction box.

HILTI CONSTRUCTION CHEMICALS, DIV OF HILTI INC — FS-One Sealant or FS-ONE MAX Intumescent Sealant.

+Bearing the UL Listing Mark

* Indicates such products shall bear the UL or cUL Certification Mark for jurisdictions employing the UL or cUL Certification (such as Canada), respectively.



Hilti Firestop Systems

Reproduced by HILTI, Inc. Courtesy of Underwriters Laboratories, Inc. January 21, 2015